

*Designed as part of a fully engineered rigging solution, blocks from Thern Stage Equipment offer convenient installation and smooth, quiet operation. With over 60 years of hoist experience, you can depend on TSE.*

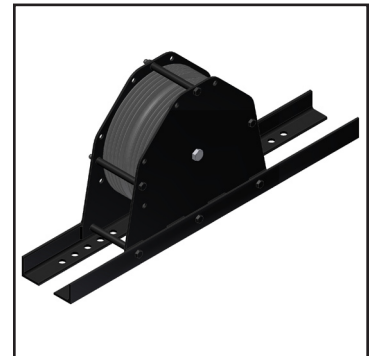

12" Head Block for upright mounting.

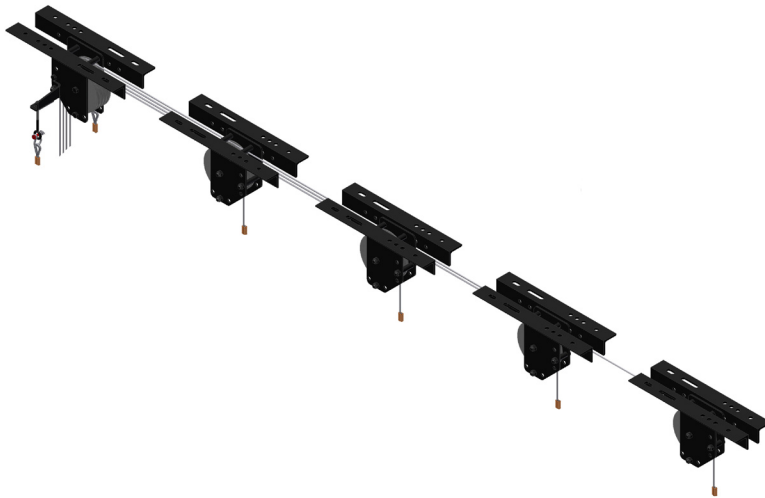

12" Head Block for underhung mounting.

## Features and Benefits:

- **Long Performance Life** provided by high quality Nylatron® sheaves and heavy-duty steel plates.
- **Compact Configuration** of up to 9 lines with a single multi-line sheave.
- **Convenient Installation** provided by adjustable mounting angles as standard.
- **Smooth and Quiet Operation** with precision ball and tapered bearings.

## Options and Accessories:

- **Mounting Options** for a variety of installation requirements.

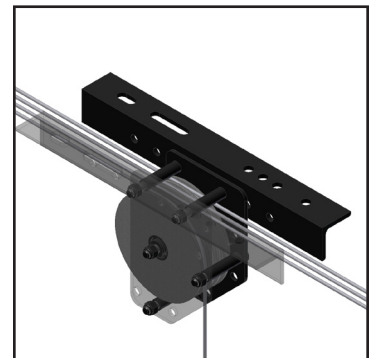

Head and Loft Block with ball bearings.

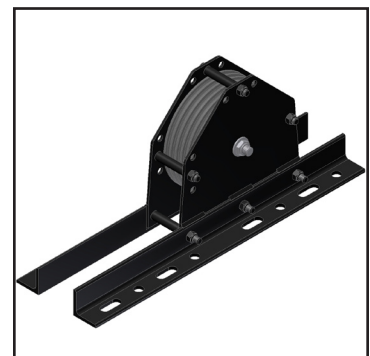

Head and Loft Block with tapered bearings.