

CURTAIN CONTROLLER

For Motorizing Curtain Track Configurations
of Almost Any Size.

TSE **THERN**
STAGE
EQUIPMENT

Product Features:

- **Lightweight and Compact** design weighs only 60 lbs.
- **Variable Speed** operation is standard up to 140 ft/min.
- **Single Phase** 115 volt operation.
- **Bronze Worm Gears** provide accurate and durable operation, totally enclosed in a cast aluminum gear case.
- **High Quality Nylatron Drum** reduces wire rope wear and ensures quiet operation.
- **Grooved Drum** for 1/8 inch wire rope with two anchor points for closed loop with up to 65 feet of travel.
- **Drum Guard** helps prevent injuries and adjusts for different orientations.
- **Shafts** turn on bearings to minimize wear and provide smooth operation.
- **4-Position Limit Switch** provides two operational and two over-travel limit positions.
- **UL Rated Motor** and controls.
- **Durable Satin Black Enamel Finish.**
- **Mounting Holes** allow for easy installation in any position.
- **2-Year Limited Warranty**

Options and Accessories:

- **Power Options** include single and three phase, and additional voltages as required.



Standard configuration shown.

- **Brake Motor** configuration is available.
- **Secondary Crank Handle** for manual operation includes remote storage and safety disconnect.
- **Control Options** include low voltage remote control, DMX controls, fully programmable touchscreen controls, and a wide range of other custom options.
- **Modified Travel Distances** for longer drapes available.

Not for lifting. For horizontal pulling only.

Thern Stage Equipment ■ 5712 Industrial Park Rd ■ Winona, MN 55987
800.553.2204 ■ fax 507.454.5282 ■ info@thernstage.com ■ www.thernstage.com

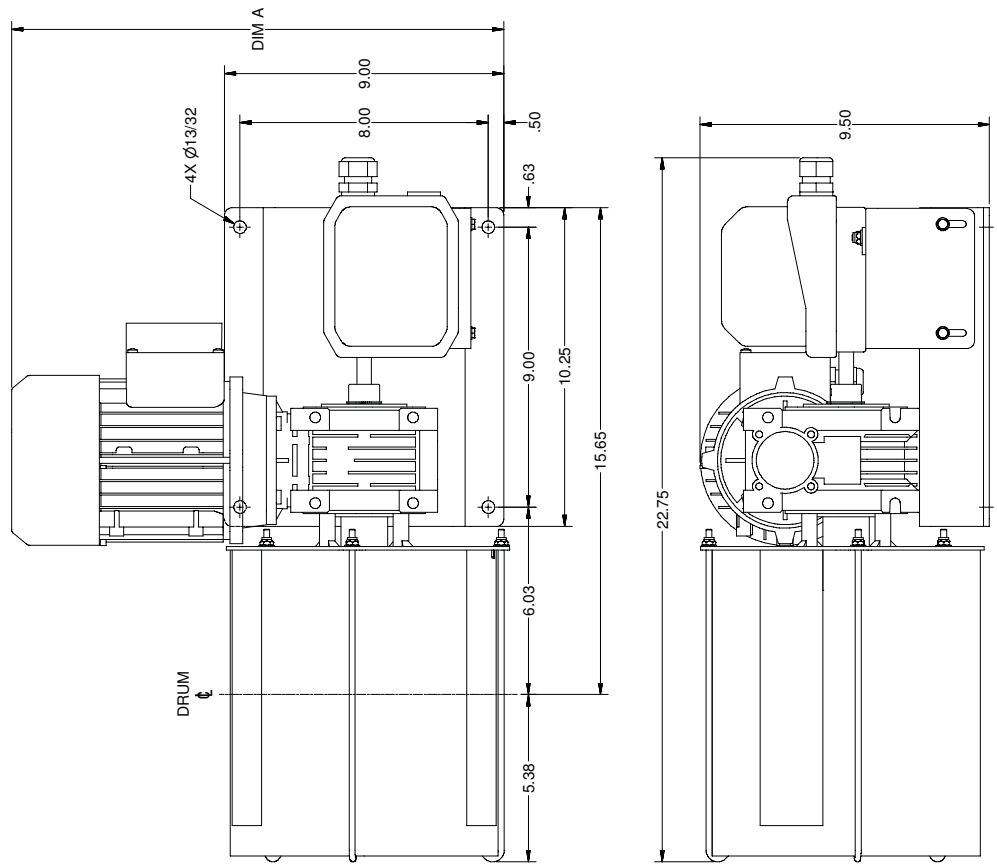

TYPICAL RISER DIAGRAM

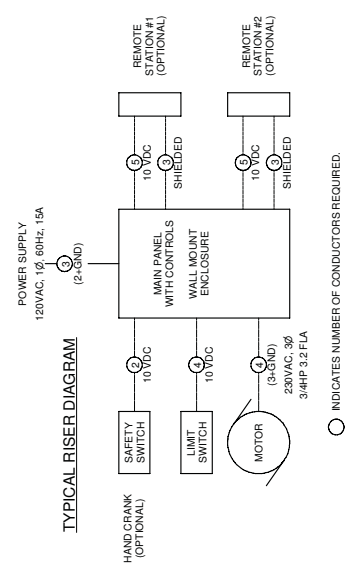

○ INDICATES NUMBER OF CONDUCTORS REQUIRED.

STANDARD SPECIFICATIONS

| | | |
|-----------------------|-------------|---------------|
| MODEL | 8DGH2 (STD) | 8DGH2 (BRAKE) |
| WIRE ROPE SIZE | Ø1/8 | Ø1/8 |
| D : d RATIO | 60 | 60 |
| MAX TRAVEL | 65 FT | 65 FT |
| STANDARD MOTOR | 0.75 HP, 3Ø | 0.75 HP, 3Ø |
| STANDARD GEAR RATIO | 25 : 1 | 25 : 1 |
| LINE SPEED (VARIABLE) | 5 - 140 FPM | 5 - 140 FPM |
| LIMIT SWITCH | 4 POSITION | 4 POSITION |
| BRAKE | NO | ELECTRIC |
| MANUAL CRANK HANDLE | OPTIONAL | OPTIONAL |
| DIM A (INCHES) | 16.00 | 18.50 |
| WEIGHT | 60 LBS | 65 LBS |

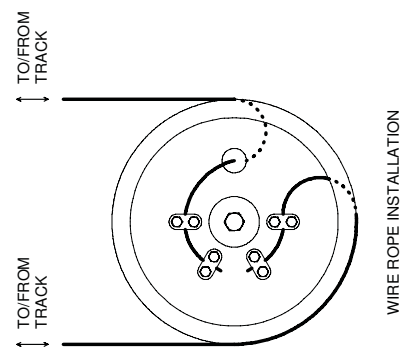

WIRE ROPE INSTALLATION

OPERATION
 LITERATURE DRAWING
 8DGH2
 THIS PRINT IS THE PROPERTY OF THERM, INC. AND
 IT IS TO BE RETURNED TO THERM, INC. UPON
 DEMAND. ANY REPRODUCTION OF THIS DRAWING
 WITHOUT WRITTEN APPROVAL BY THERM, INC.
 IS STRICTLY PROHIBITED.

REVISIONS
 REV. DATE: 12/27/2008
 DRAWING D3272
 1:2
 3/2/2008

APPROVALS
 DESIGNED BY: JCA
 CHECKED BY: JCA
 DRAWN BY: JCA
 DATE: 12/27/2008
 THERM, INC.
 1000 W. 100th St.
 P.O. Box 1001
 Fritch, TX 75634
 PHONE: 409.442.2222
 FAX: 409.442.2222